



AR1623-39



Key Features

- Front and Rear Access Openings
- 4 Configurable IO panels
- Cross flow vents with fan mounts
- Mounting points for Fixture and Optional Shelving
- 19in Rack Mountable
- High RF Shielding

Mechanical Specifications

Dimensions	Width	Depth	Height
Internal Dimensions	395.21mm(15.56in)	600.00mm(23.62in)	966.21mm(38.04in)
External Dimensions	460.46mm(18.13in)	695.17mm(27.37in)	1000.00mm(39.37in)
Weight	Approx 100 lbs		

Typical RF Shielding

Range	Isolation
100 to 2000 MHz	> 70 dB
2000 to 3000 MHz	> 70 dB
3000 to 6000 MHz	> 70 dB

Ordering Information

Part Number	Item
F180000-00	80mm 36CFM Fan, with 120VAC to DC Adapter
MPBA0000-00	Nonconductive Shelves and Rail Set(Includes 2 L/R Rails and 2 Shelves)
MHB0000-00A	Rack Mount Tabs

Concentric Technology Solutions, Inc. TEL: 817-503-8862 FAX: 817-503-8866 Email: CTS-Sales@ctscorp-usa.com

ARMR PHOENIX, AZ

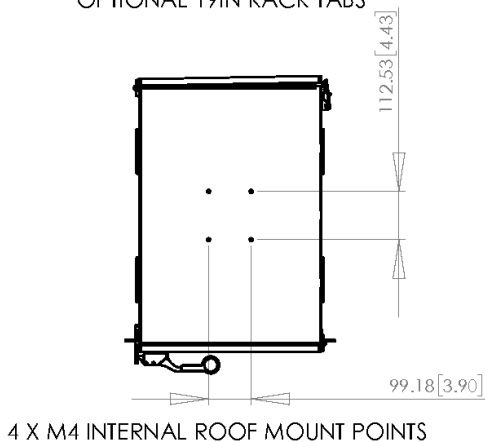
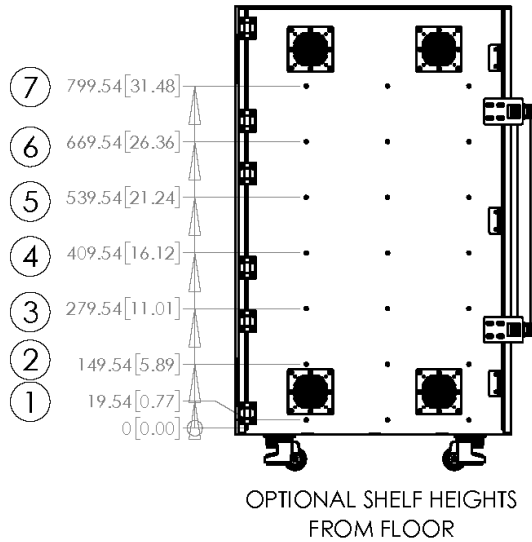
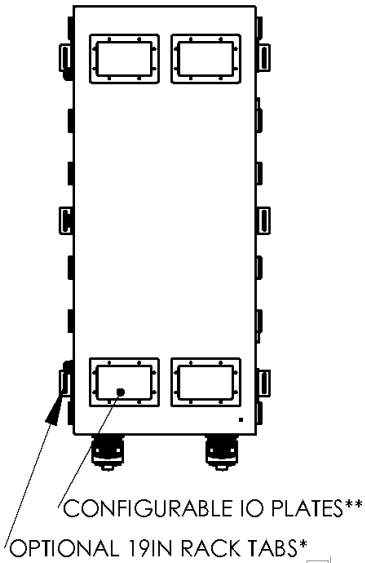
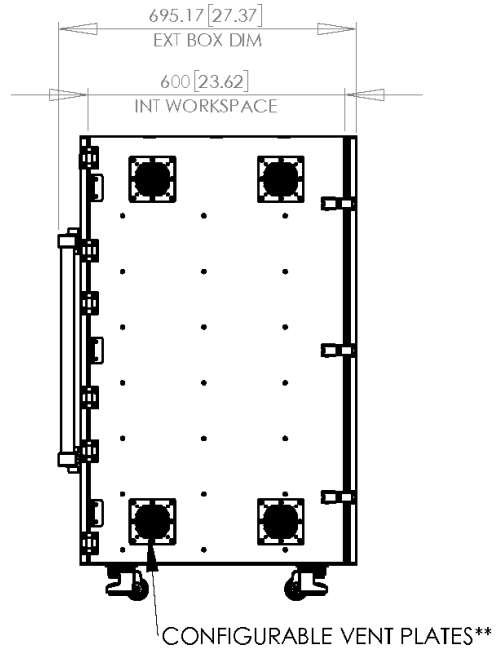
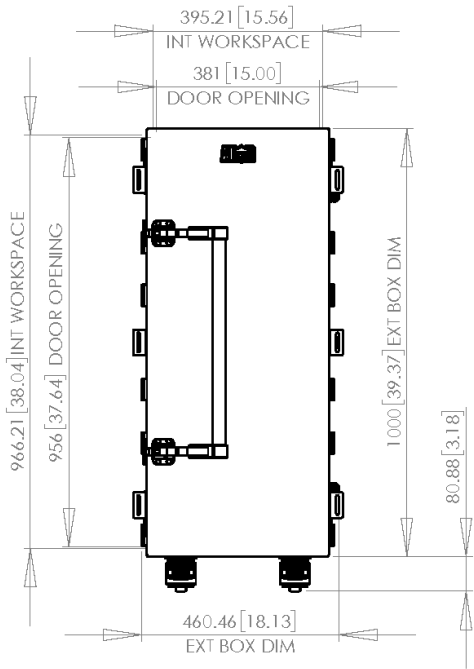

* Rack shelf is recommended for mounting

**See list of available options

Shelves, Fixture Mounting, Fans, as well as custom connectors and options are available through your sales representative

mm(in) unless otherwise specified
 Drawing not to scale
 doc v1.0