



# AR1623-26



## Key Features

- Front and Rear Access Openings
- 4 Configurable IO panels
- Cross flow vents with fan mounts
- Mounting points for Fixture and Optional Shelving
- 19in Rack Mountable
- High RF Shielding

## Mechanical Specifications

Dimensions	Width	Depth	Height
Internal Dimensions	395.21mm(15.56in)	600.00mm(23.62in)	621.21mm(24.46in)
External Dimensions	460.46mm(18.13in)	687.79mm(27.08in)	655.00mm(25.79in)
Weight	Approx 70 lbs		

## Typical RF Shielding

Range	Isolation
100 to 2000 MHz	> 70 dB
2000 to 3000 MHz	> 70 dB
3000 to 6000 MHz	> 70 dB

## Ordering Information

Part Number	Item
FA20000-00	Fan,120mm, 120VAC, 110CFM
MPBA0000-00	Nonconductive Shelves and Rail Set(Includes 2 L/R Rails and 2 Shelves)
MHB0000-00A	Rack Mount Tabs

Concentric Technology Solutions, Inc. TEL: 817-503-8862 FAX: 817-503-8866 Email: CTS-Sales@ctscorp-usa.com

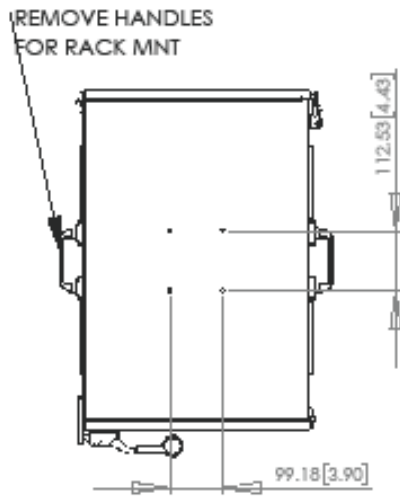
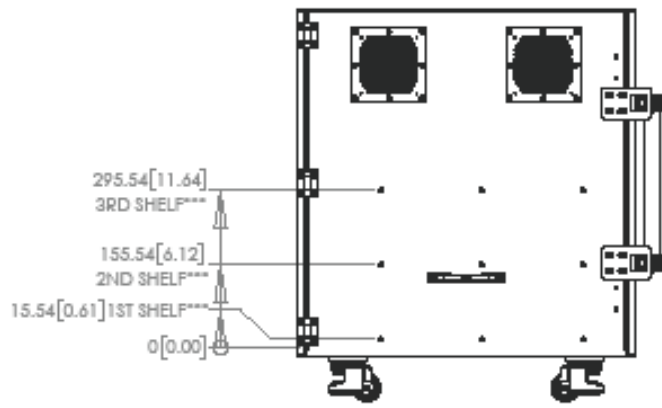
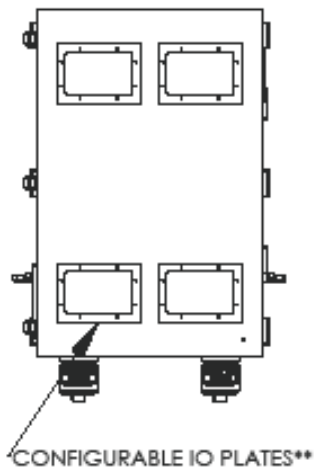
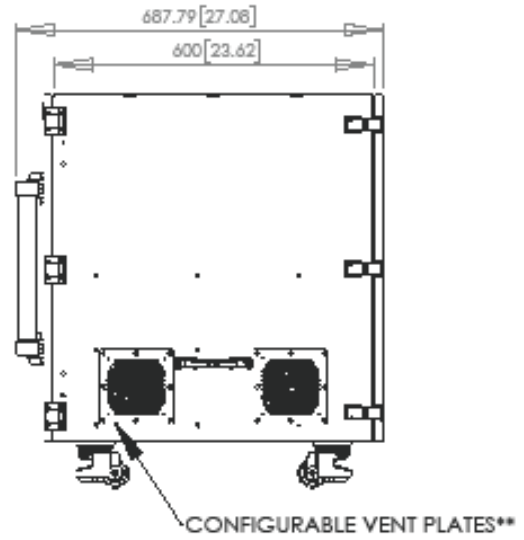
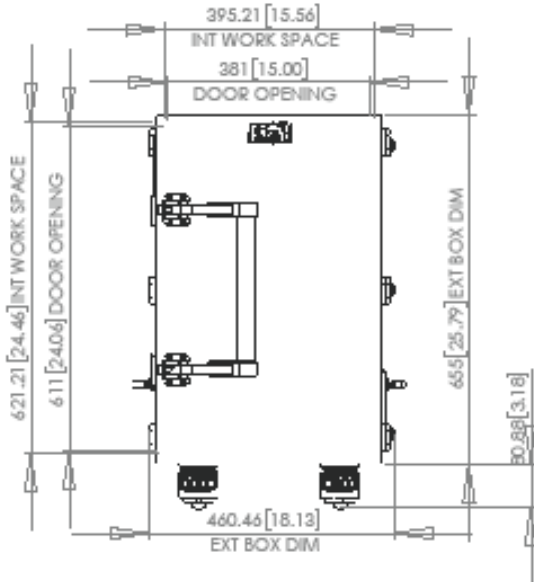

4 X M4 INT ROOF MOUNT POINTS

\* Rack Shelf is recommended for mounting

\*\*See list of available options

\*\*\*Shelves optional

Shelves, Fixture Mounting, Fans, as well as custom connectors and options are available through your sales representative

mm(in) unless otherwise specified

Drawing not to scale

doc v1.0